



TECHNICAL TREND OF SIGNALING SYSTEM AND LATEST LRT SIGNALING SYSTEM

NORISHIRO ISHII
Deputy General Manager

Yoshikazu Saito
Engineer

KYOSAN ELECTRIC MFG. CO., LTD.

SUMMARY

Railway safety can be said to be a history of troubleshooting.

And the world has come to require railways to reinforce convenience and service quality while looking safety as a matter of course. In such circumstances, midsize cities and the suburban areas of large cities are faced with transportation difficulty that demand is not so great as to require railway but cannot be dealt with only by busses and other automobiles. As a new transit system like AGT (Automated Guide way Transit) that is safe and can meet such demand, has been introduced to play an important role in such regions.

This paper analyzes the technical trend of signaling system and introduces the newest signaling system that was applied to Singapore Sengkang/Punggol LRT, or an advanced AGT.

1 INTRODUCTION

It is the common sense of railway users that railway is a safe means of transportation. Recent railway users strongly require not only safety but also punctuality, promptness, convenience and comfort. Besides, their expectations are going beyond the original purpose of railway, i.e. the transportation of passengers. For example, universal design, barrier-free environment, high-quality service and human-friendliness are expected of railways.

It seems that these requirements and expectations will lead railway to link all facilities and equipment to achieve an integrated transportation network in the future. (Figure 1)

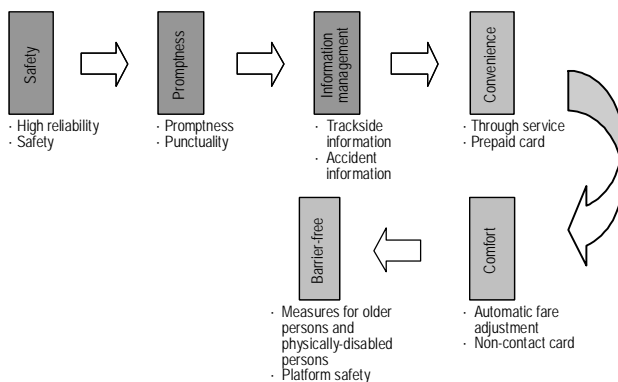

Figure 1: Requirements for Railway

2 TECHNICAL TREND OF SIGNALING SYSTEM

2.1 Progress Of Signaling System

Railway transportation initially started with visual operation. But because accidents and operation blockages occurred more frequently as the number of trains increased, more importance was given to safety, and the technologies such as fail-safe and foolproof systems that became the basis of signaling system were established. Then, as microprocessor was developed and ME technology was applied in the field of signaling system, computer based interlocking equipment was developed and aggregation progressed by integrating equipment that had been distributed according to functions. Today ATP on-board profile system is already put to practical use. It can be said that we have entered the age of intelligent cab system where control profile are created by on-board processor. Besides, as radio applied technologies are established in the field of signaling, the communication base that aims at equipment integration and autonomous control is more strongly required. (Figure 2)

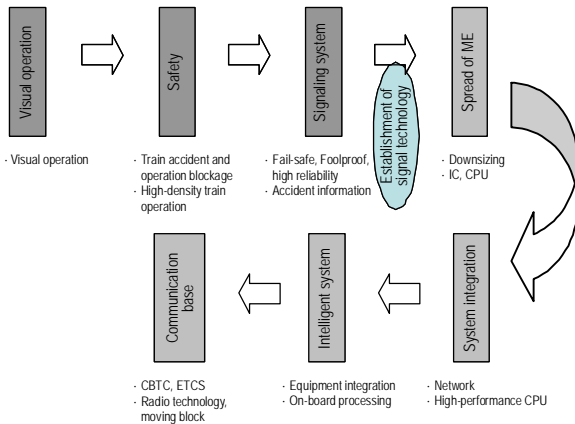

Figure 2: Progress of Signal

2.2 Progress Of Interlocking Device

Concerning the interlocking technology, through the age where railway system was operated mainly by station masters' signs, interlocking device was developed to cope with increasing number of trains. This interlocking technology was established as a result of building up the measures against accidents. The technology has evolved into computer based interlocking as well as centralized interlocking as its application.

In the future, the technology will be integrated with train control system to form an integrated signaling system. (Figure 3)

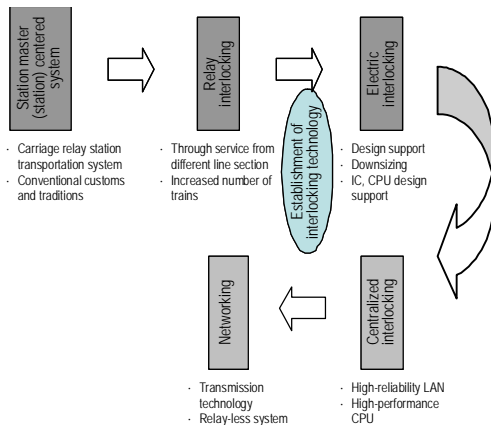

Figure 3: Progress of Interlocking System

2.3 Progress Of Train Control System

Train control system initially started as cab warning device and developed into AWS and ATP as a result of building up the measures against accidents, like interlocking technology. At that point, train control technology was basically established. Then, like interlocking technology, it has evolved into ME technology applied train control system.

In the future, it will drastically change to a train control system that uses digital technology, such as on-board profile generation and moving block, and signal encoding technology. (Figure 4)

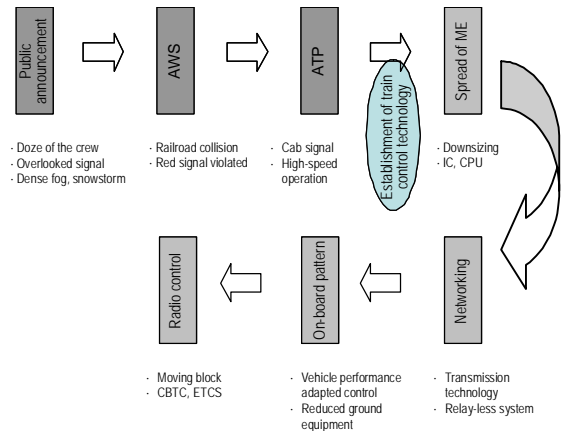

Figure 4 : Progress of Train Control System

2.4 Progress Of Traffic Control System

Slightly different from interlocking and train control systems, traffic supervise system has been developed relied on the safety that was achieved by interlocking and train control systems. Namely, in order to optimize the works of traffic controllers and signal handling personnel and to centrally manage the operation of trains, CTC and ATS were developed and employed. It can be said that at that point traffic control technology was established. In the future, like interlocking and train supervise technologies, it will continue to develop toward the integration of all systems related to railway transportation, including electric power supply management system and rolling stock management system.

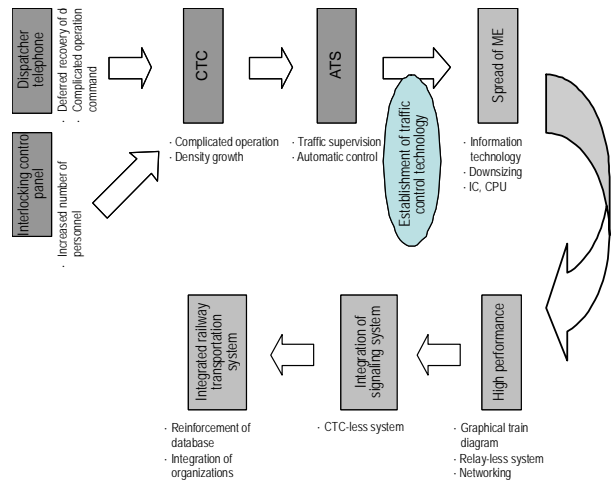

Figure 5 : Progress of Traffic Supervise System

2.5 Radio Technologies Application

The progress of individual system is as described above. It is the spread of computer based ME technology that brought about a change on signal technology. It can be said that the reliability and functionality of signaling system have been improved dramatically by computer, which implemented the know-how of signaling that had been accumulated till then.

It seems that radio technology will be a key to future signaling systems.

As Figure 6 clearly shows and we can easily imagine, radio technology can network all equipment.

As moving block that uses radio wave such as UHF and VHF is actively studied now, the train control system that uses satellite communication, which is represented by GPS, may be achievable in the near future. (Figure 7)

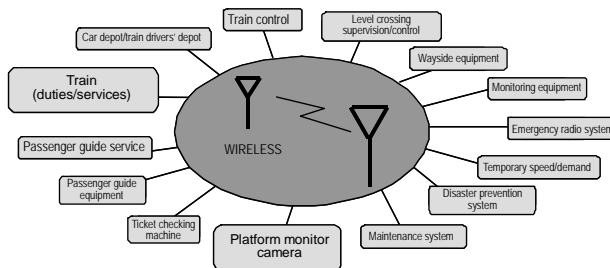

Figure 6 : Wireless Network

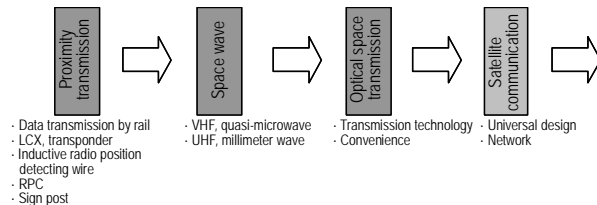

Figure 7 : Radio Applied Technology (Information Transmission System)

3 TREND OF NEW TRANSIT SYSTEM

3.1 History Of The New Transit System Of Japan

There are provincial cities and suburban areas of large cities where transportation demand is not so great as to require railway but cannot be dealt with only by busses and other automobiles.

To meet such demand, a project of "new transit system" was planned in late 1960s. In 1974, to promote the development of new transit system, Japanese government established a grant-in-aid system to aid part of the construction cost of infrastructure, such as struts and girders, of new transit system, as part of road improvement project.

Using the grant-in-aid system, the development of new transit system was carried out in various regions. However, because there was no unified technical standard for new transit system, each system had to be designed individually, which resulted in increased construction cost and incompatibility.

To solve this problem, new transit system was standardized to define basic specifications in 1983. As a result, new transit systems with easy designing, low construction cost and compatibility have being developed.

The development of new transit system in Japan as of 2005 is 14 routes in service operation (9 routes of new transit system, 4 routes of urban monorail and 1 route of maglev system) and 1 route under construction (new transit system).

3.2 Features Of The Signaling System Of The New Transit System

3.2.1 Signaling system

Because new transit system uses rubber tire or magnetic levitation, unlike conventional railways, it is impossible to detect trains by short-circuit of rails.

Therefore, mainly the train detection and control systems that are based on system, where information is communicated between cab and ground facilities via loop coils.

There are two types of signaling system for new transit system: one based on block system and the other based on CBTC.

Either system has advantages. In selecting a signaling system for a new transit system, it is important to understand the advantages of both types of signaling system and select one that can meet the requirements of the relevant transit system.

- Block system

For the signaling system that is based on block system using loop coils, it is necessary to install loop coils at certain intervals depending on headway. In this system the boundary characteristic of train detection is clear, conventional hardware-based signal processing is employed, and as a result safety can easily be verified. For all of these reasons, this type of signaling system is suitable for the routes with tight headway.

- CBTC

On the other hand, for the signaling system that is based on wireless CBTC system, ground facilities can be reduced by using wireless facilities. However, detecting train position is made on board and the response and processing of radio equipment depend on software, sufficient verification of safety is indispensable for the routes with tight headway.

3.2.2 Driverless system

Because on new transit system trains run on dedicated tracks, basically driverless operation is employed.

The method and mode of driverless operation depend on sections, such as commercial sections, shunting between main line and car depot, and marshalling in car depot.

For construction of driverless system, it is necessary to employ the system that is the best for the mode of driverless operation in individual section.

- Main line operation

In the driverless system, since each station is equipped with platform edge doors, high accuracy is required for train stop. If failure occurs on a vehicle, the train is automatically operated to the nearest station to let passengers get off so that there will be no influence on other service operations (i.e. when the nearest stations is in the back of the train's traveling direction, the train is operated in reverse to the station)

- Ramp up and down

With regard to ramp up of vehicles in the sections between car depot and main line, as not all the services start from the station nearest to the car depot, quick out-of-service operation to its starting station is necessary for each service that starts from one of the stations other than the station nearest to car depot in order to maximize main line's operational capacity. In this case, the trains are required to pass through all the stations at decreased speed on the way to their own starting station or required to stop some stations without door operation. Also regarding ramp down of vehicles in these sections, for each service that its arrival station is not the one nearest to the car depot, automatic out-of-service operation to the car depot is required.

- Operation in car depot

Because there are many vehicles to operate, operation must be performed rapidly using the vehicle operation or maintenance system. A system that enables efficient operation needs to be constructed. For example, it must be possible for the operators of car depot to operate vehicles by themselves with no influence on the train operation of main lines or to stable or shunt multiple vehicles running on one track.

3.2.3 Train supervision system

Because basically driverless operation is performed on new transit system, functions such as stopping trains at stations, monitoring vehicle condition, and controlling individual train are important.

OCC operators, monitor the condition of vehicle and platform doors at the station where a train is stopped. In an emergency, they are able to prohibit the train from departing the station, prohibit other train to enter the station, and stop feeding.

3.3 Operation & Maintenance (O&M)

3.3.1 Operation

Maintenance of new transit system is performed based on ATS system.

The ATS system that controls security can monitor and control stations and vehicles as well as take emergency actions.

The functions that can be performed by ATS system include: train tracking, route control, passenger guide control, individual train control, station stop control and emergency operation.

It also monitors various conditions, such as traffic condition, condition of ground facilities and condition of on-board equipment.

Furthermore, it has a function to record operation data and raise an alarm in case of condition change.

3.3.2 Maintenance

The condition of failed equipment is monitored by ATS system, which has the function to promptly pinpoint defective part.

In addition, electronics are redundant so that parts can be replaced without system down.

An operation recorder is built in main equipment so that in case of system error, the conditions before and after the error occurrence can be recorded on the IC card or recording paper of the recorder. In this way, the system supports troubleshooting and improves maintainability.

3.4 Future Prospects For The New Transit System

New transit system plays an important role in the transportation inside cities or facilities.

Signaling system not only assures safety but also manages all aspects of train operation.

While we have recently experienced remarkable technical innovations, signaling system also has achieved a remarkable development.

It seems that signaling system will proceed toward communication based system in the future. However, currently introduced CBTC system differs depending on route, making it difficult to evaluate safety of planed CBTC systems, and is still developing.

Especially when a new transit system with 100 seconds or shorter headway is constructed, it is necessary to carefully and sufficiently verify safety.

We hope that design and inspection standards will be established in the future.

4 SINGAPORE SENGKANG / PUNGGOL LRT SIGNALING SYSTEM

4.1 Abstract

Sengkang/Punggol LRT was constructed from Sengkang and Punggol Station of the North East Subway Line, which runs radially from the centre of Singapore, as the means of transportation for the people living in Sengkang New Town and Punggol 21 New Town that spread along the route. Sengkang LRT was opened in January 2003 and Punggol LRT in January 2005, and completely driverless operation is performed not only on revenue service on main lines but also for the shunting works in car depot. (Figure 4.1.2)

Sengkang/Punggol LRT is a turnkey project that was ordered by Singapore government, Transport Authority (LTA), and is operated and managed by SBS Transit (SBST).



Figure 8 : Wireless Network



Figure 9: Sengkang and Punggol Line Map

Prior to this project, in Singapore 3 routes of subway and 1 route of new transit system are in service. Sengkang/Punggol LRT is the second route of new transit system. (Figure 4.1.1)

In developing relevant products, EMC standard (IEC61000) was applied to hardware while safety audit and management system audit (software audit) were performed on software. Therefore, the products are able to meet international quality requirements.

4.2 Specifications

4.2.1 Route

Sengkang Line of Sengkang/Punggol LRT is a double-track line with the total length of approx. 10 km. It starts from Sengkang Station of the North East Line and runs on the letter-8-shaped route so that each loop covers east and west area of Sengkang New Town. Total 14 stations are arranged along the route: 5 stations on East Loop, 8 stations on West Loop, and Town Centre Station (STC).

Punggol Line of Sengkang/Punggol LRT runs on the north of Sengkang. Like Sengkang LRT, it is a double-track line with the total length of approx. 10.3 km and 15 stations. It starts from Punggol Station of the North East Line and runs on the letter-8-shaped route so that each loop covers east and west area of Punggol 21 New Town. Sengkang Line has a car depot to store and maintain vehicles that are used on Sengkang Line or Punggol Line.

4.2.2 Specifications

Table 1 shows the basic specifications for Sengkang/Punggol LRT.

Service length in kilometers	Sengkang	10 km (double track)
	Punggol	10.3 km (double track)
Number of stations	Sengkang	14
	Punggol	15
Transportation capacity	Sengkang	8,400 passenger/hour (maximum, one way)
	Punggol	9,800 passenger/hour (maximum, one way)
Vehicle guide way system	One-side guidance system	
Number of operated trains	Sengkang	Max. 16 trains
	Punggol	Max. 18 trains
Train formation	1-car train	
Minimum headway	Under 90 sec.	
Maximum speed	70 km/h	
Minimum radius of curvature	Main line 25 m/car depot 15 m	
Steepest gradient	Max 60‰	
Electric system	750 VDC	
Signal indication system	Brake control with continuous curve by cab signal	
Operation system	Automatic driverless operation	

Table 1

4.3 Design Concept

The system is based on the following key solutions.

- 1) **Safety**
 Proven signaling technology for railway is employed in order to realize a highly safe system with regard to vehicle collision avoidance, protection in switching areas of guide way and safe getting on and off on platform.
- 2) **Operability**
 A state-of-the-art traffic control system is used in order to maximize system operability, with various automated functions and properly designed man-machine interface.
- 3) **Hierarchical structure**
 The system is constituted in a hierarchical structure with redundant configuration in order to ensure high system availability.

4.4 Configurations

4.4.1 System configuration

Figure 8 shows the configuration of the entire ground system; Figure 9 shows the configuration of on-board system.

In the central equipment room (CCER), computer based interlocking equipment (CBI), automatic vehicle protection (AVP)/vehicle detection (VD) system, station control device (SCD) and automatic vehicle supervision (AVS) system interfaces are interconnected via a 100 Mbps fail-safe optical LAN (CI-LAN) to minimize cabling inside the CCER.

In addition, between CCER and individual station equipment rooms(SER), 100 Mbps fail-safe optical LAN for field(ET-LAN) was constructed along the entire route for connecting between central devices and station devices of both computer based interlocking equipment and station control device to minimize cabling between CCER and SERs.

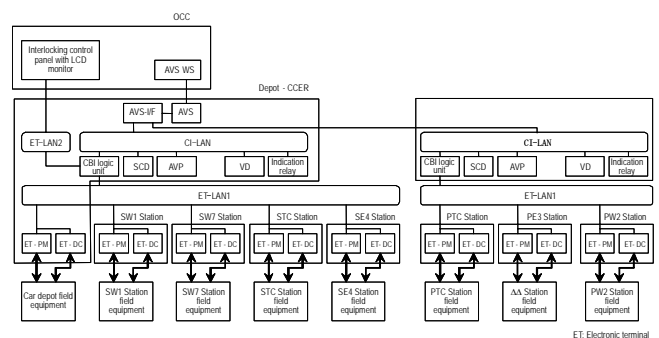

Figure 8 : Singapore LRT System Configuration

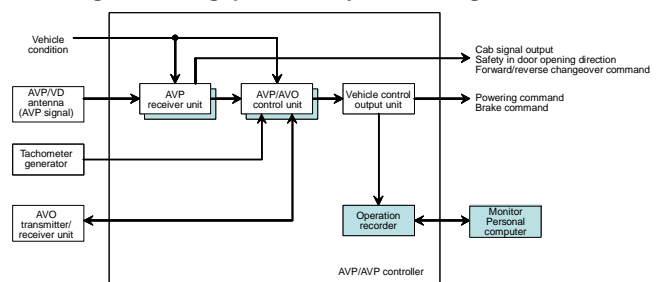

Figure 10: Function Block Diagram of AVP/AVO Controller

4.5 Features

4.5.1 Automatic Vehicle Protection (AVP) system

AVP subsystem is installed in the depot central control equipment room (Depot CCER) for Sengkang Line and the depot CCER for Punggol Line. And the AVP's vital microprocessor-based state-of-the-art design with a highly versatile modular scheme achieved centralization of all track circuits.

This system controls train speed and the direction of each train as well as performs other duties, such as the permission of door operation at station.



Figure 11: AVP/VD Bay

• **Vehicle Detection (VD)**

Because of rubber tire system without rail, it is impossible to detect trains by short-circuit of rails. On the other hand, utilizing the system to detect trains by short-circuit of feeder rails, there is a probability that no train may be detected due to malfunction of shunt performance. Therefore, the contact less Vehicle Detection (VD) system using loop antennae laid on the guide way is used. It employs the electro-magnetic induction principle, best suited to rubber-tired transits for vehicle position detection. It uses the Check-in and Check-out scheme that has a well proven records of safety and reliability. Despite the fixed blocking scheme, the shortly subdivided blocks have allowed it to achieve high-density operation with a minimum headway of under 90 seconds.

• **Computer Based Interlocking (CBI) system**

Two independent CBI systems are incorporated in Sengkang system as well as in Punggol system. Individual CBI is a microprocessor-based interlocking that governs overall traffic safety for each system in centralized mode. It works in coordination with the AVP, AVO and AVS subsystems, all incorporated into the system through the common fail-safe network. Remote electronic terminals at stations are used to interface with the field equipment connected through fibre-optic cables.

Besides, even if AVS system is down due to failure, CBI subsystem controls each subsystem of AVP and AVO to continue driverless operation.

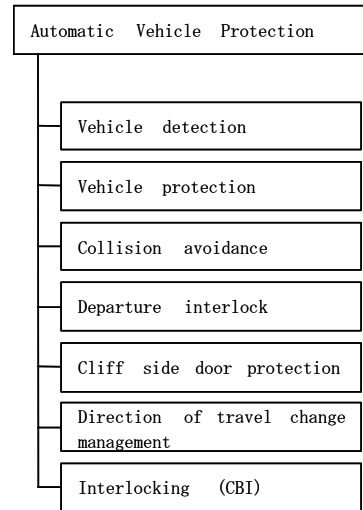

Figure 12: AVP functions

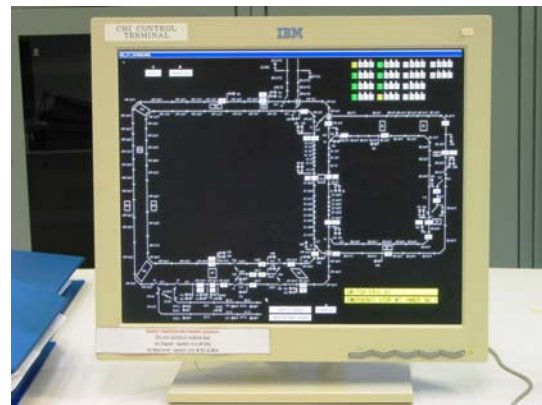

Figure 13: CBI Control Terminal

4.5.2 Automatic Vehicle Operation (AVO) system

The AVO acts as the core subsystem in driverless operation and performs required automatic vehicle control functions, such as programmed station stop, vehicle door operation, dwell time management and starting control at stations. In addition, in synchronous operation mode, the AVO automatically adjusts vehicle dispatch timing in accordance with the ID number and location of the vehicles on the route ahead of the station. For this, vital processor is installed in the centre control equipment room (CCER) as well as in the equipment room of each station (SER) to integrally control AVO (automatic vehicle operation) related vital and non-vital functions of all stations.

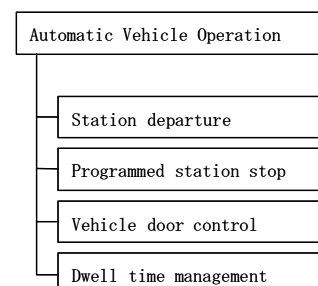

Figure 14: AVO functions



Figure 15: Station Control Device Bay

4.5.3 Automatic Vehicle Supervision (AVS) system

The AVS system manages the entire operation of the system, from station broadcast output and fully automated functions to the control of vehicle's headlight and air conditioners. At the Operation Control Centre (OCC), a number of AVS workstations provide the operators facilities in real time basis. Suitably designed system operation modes, e.g. Automatic Double Ring Synchronous, Automatic Letter-8-Shape, and the like sustain flexibility in operation.

The data logging system (DLS) connected to AVS computer records all events that occur during operation to facilitate quick troubleshooting in case of failure.

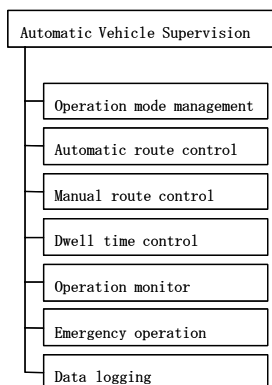

Figure 16: AVS functions



Figure 17: AVS Workstation

4.5.4 On-board equipment

AVP & AVO controller that is integrated by vital processor is the heart of the on-board equipment for automated driverless vehicle operation. Its compact packaging allows easy installation in the limited space on a vehicle. It allows various automatic vehicle control functions in a fail-safe, reliable manner, such as propulsion/braking control, constant running, Train Automatic Station stop Control (TASC), over-speeding protection, direction control, etc. The AVO Transmitter & Receiver communicates with the wayside AVO while station dwelling to exchange control commands and on-board status, including vehicle door operation. It also provides accurate position information as AVO position markers are detected when train passes over them, for fine-tuning of the on-board distance and train position calculation. The VD Transmitter is another on-board signal device that transmits the Check-in and Check-out signals to the AVP Loop Antenna for the safe wayside train detection.

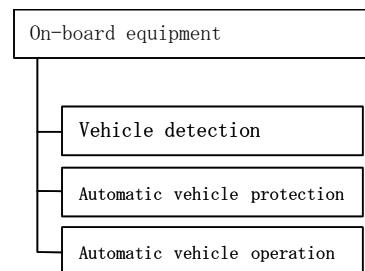

Figure 18: On-board functions



Figure 19: AVP & AVO Controller

5. CONCLUSION

This thesis describes technical trend and latest LRT. Basic of signaling technology is already established. Signaling equipment will be miniaturized and shift to software based system by utilizing high MPU ability. However we must not forget the signaling principle.